

# Technical News Bulletin

April 1995

## 3000 Series Process Control

### 1. Introduction

Quick Change Plunger Mechanisms Series 3000 are now provided with an additional operating enhancement. To permit optimization of plunger parameter settings, the mechanisms are equipped with a sensor to monitor the pressing action of the plunger stroke. A purchasing agreement reached between Emhart Glass and Heye-Glas of Obernkirchen, Germany made it possible to use the well-known Heye Process Control technology for this purpose.

Essentially, the 3000 Series Process Control makes it possible to monitor the pressing action of all plunger pistons of IS or AIS machines. A number of key forming characteristics are displayed on the monitor as graphics screens and can be accessed by the controller. In this manner, actual trends can be compared with setpoints to optimize forming parameter settings (**Figs. 1 - 5**). Automatic gob weight control and prompt recognition of a potential malfunction boost production efficiency.

### 2. Plunger Position Measuring System

To determine the plunger position in the mold, the piston position is measured relative to the plunger cylinder. Measurement of the final 40 mm of the piston upstroke is sufficient to evaluate the performance of the pressing process.

The required measuring sensor for piston travel is located on the upper end of the cylinder (**Fig. 6**). An aluminum sleeve on the piston slides in unison during piston travel over the sensor coil. The alteration of the sensor coil inductivity initiates a signal which is processed by the control system to determine the piston position. The sensors can be calibrated semi-automatically during machine operation without the need of additional measuring devices. Automatic temperature compensation ensures that the piston position measuring values are measured with a stable tolerance of  $\pm 0.1$  mm.

### 3. Quick Change Plunger Mechanism

Apart from the TG 3" plunger mechanism, the full range of Emhart Quick Change Plunger mechanisms can be provided with the sensor system. The integration of the sensors in the Quick Change plunger mechanism essentially requires some modifications of the mechanism. Since existing mechanisms have proven to be unsuitable for this purpose, a new range of Quick Change Plunger mechanisms was designed. These mechanisms are available with or without sensors. They easily permit subsequent sensor installation if originally supplied without. The new range of mechanisms requires no alteration of plunger mechanism mounting parts if previous Quick Change Plunger mechanisms must be replaced.

### 4. Control Loops

The total average value of all plunger positions is the decisive variable for the gob weight control. Deviations from the setpoint value activate the feeder tube adjustment control loop. Tube height adjustment is carried out by a remote motor and gear unit (**Figs. 7 and 8**). A selector switch on the remote drives permits operation in either the manual or automatic mode. In the automatic mode, the stepper motor drive is connected to the output shaft by means of an electromagnetic clutch.

**Fig. 9** shows a typical installation arrangement with a 555 Feeder System where the tube height control loop is connected directly to the 555 Tube Height Controller. An optional switch feature can be installed to select the Powers Gob Weight Control System in case of Blow & Blow operation.

An additional control loop is available for equalizing weight differences between adjacent gobs of IS machines in multigob operation. This control loop uses the difference of the plunger position average values as the regulating variable. In the case of double gob operation, one feeder plunger will be centered and fixed. The adjacent plunger is equipped with a motor and gear unit (**Fig. 7**). Vertical adjustment is performed until the difference between the plunger position average values is zero. In the case of IS machines in triple gob operation, one plunger is fixed while the others are equipped with an adjustment drive each.

In the case of feeder mechanisms with only one plunger for multigob operation, a horizontal adjustment of the plunger is performed to equalize the weights between the inner and outer gobs (**Fig. 8**). The adjustment drive directly acts on one of the adjustment spindles of the plunger carrier cross table.

## 5. Application

The 3000 Series Process Control System can be integrated in single configuration or tandem IS or AIS machines and is capable of supporting up to 40 sensors for plunger monitoring.

The 4 control loops available are used on single configuration machines for tube height control and up to 3 feeder plunger position controllers. In the case of tandem machines, the four loops are used for 2 tube height controllers and 2 feeder plunger position controllers.

## 6. Specifications

Refer to the following drawings for selecting 3000 Series Process Control equipment:

- 62-D-11011 3000 Series Process Control - Master Assembly
- 62-D-11012 Plunger Mechanism Selection
- 62-D-11022 Controller
- 62-D-11023 Machine Cabling
- 62-D-11025 Section Box Cabling
- 503-D-243 Feeder Equipment

## 7. Technical Data

- Voltage 100 V - 260 V, single-phase
- Frequency 50 Hz/60 Hz
- Power consumption 600 VA with air conditioner  
300 VA with heat exchanger

Ambient temperature max. 53° C with air conditioner; max. 43° C with heat exchanger

## 8. Mold Design

The plunger design must be altered for increased plunger overtravel to permit the screen display of the plunger position. Data Sheet 62-C-6621 gives the design recommendation for NNPB plungers and finish equipment.

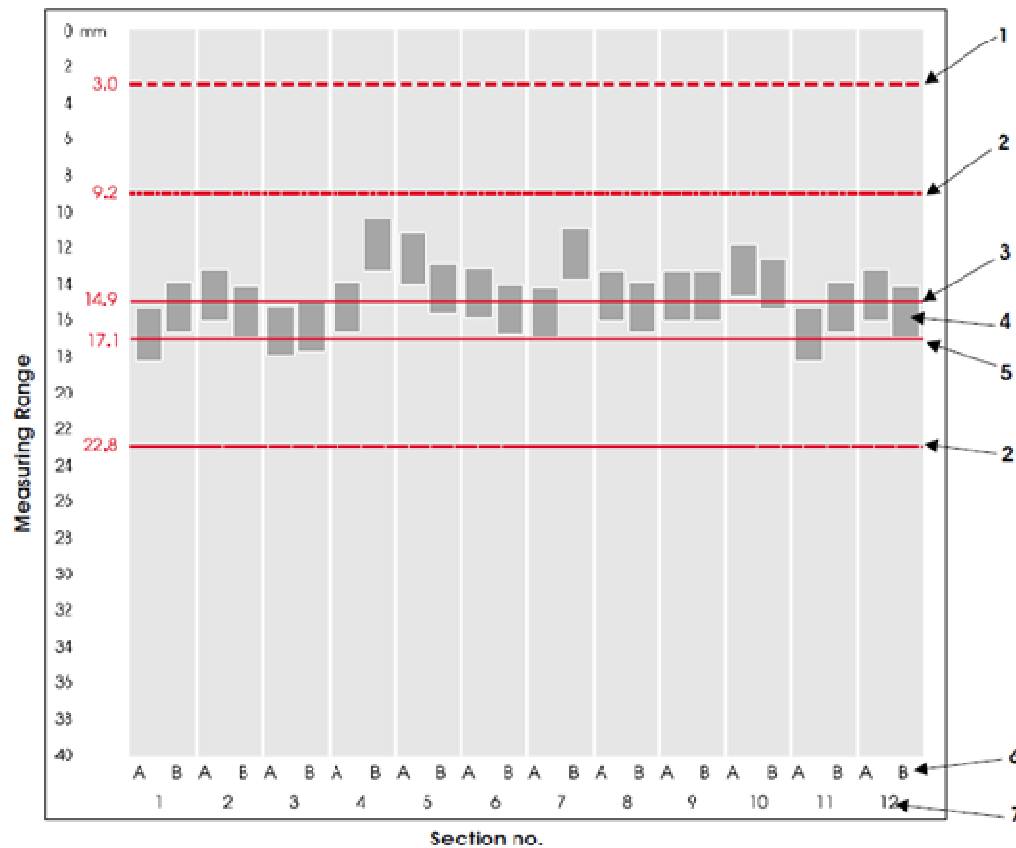
## 9. Features and Benefits

### FEATURES:

- Easy operation and operating results at a glance
- Semi-automatic sensor calibration, no tools required
- Automatic temperature compensation
- Software diagnostics
- Minimum maintenance requirements
- Extensive local language capabilities for program dialog (English, French, German, Italian, Spanish, Portuguese, Dutch, Turkish)

### BENEFITS:

- Easy surveyability of the entire plunger process
- Prompt determination of potential malfunctions
- Setpoint control of plunger limit positions and dwell time
- Plunger motion display
- Weight fluctuation control between individual gobs
- Analysis of plunger pressing motions
- Ambient influences on feeder are easily determined

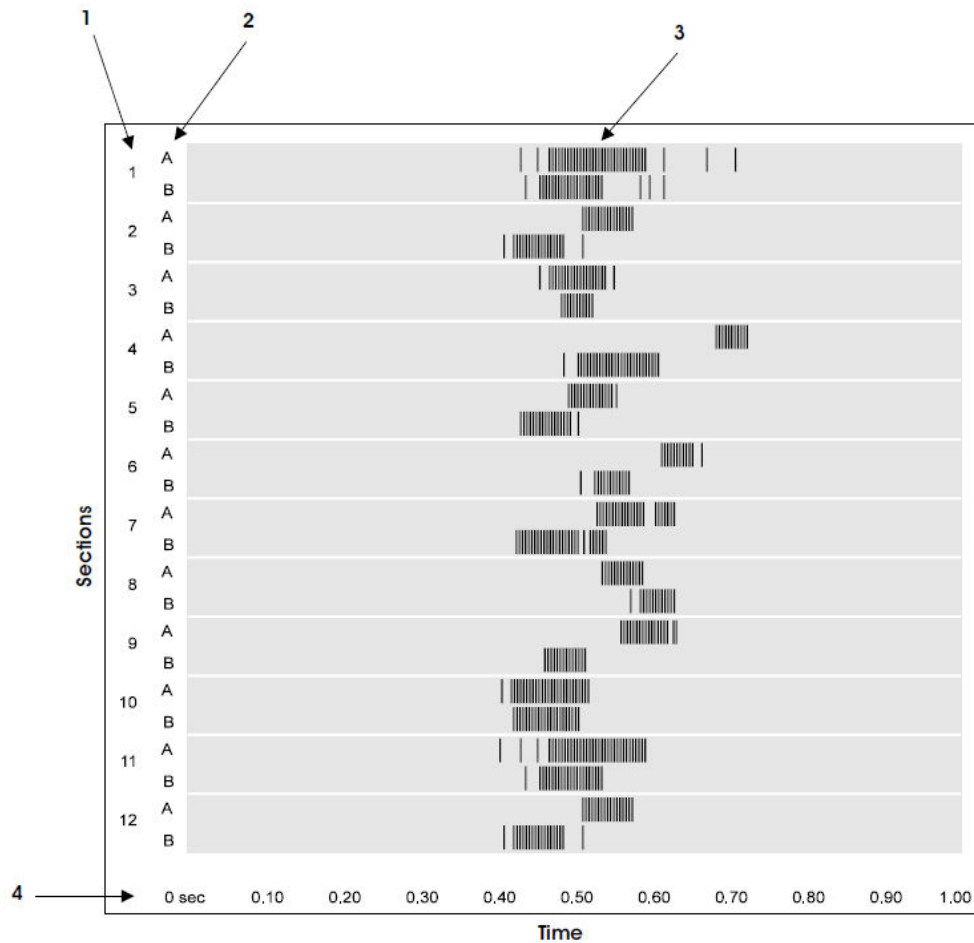


**Fig. 1:** Plunger End Positions

- |  |  |
|--|--|
| 1. Limit line of control range             | 5. Guide ring / Plunger reference line |
| 2. Limit lines for plunger end position    | 6. Outer (A) and Inner (B) cavity      |
| 3. Setpoint of plunger end position        | 7. Section number                      |
| 4. Plunger end positions of last 40 cycles |  |

The last 40 positions of the plunger are shown as green lines. Bars are formed by short-term gob weight deviations. Upper and lower limit positions (2) as well as the setpoint value (3) of the plunger position average values and a reference line (5) permit quick orientation for the machine operator. This display shows:

- Volumetric differences of blank molds
- Short-term gob weight deviations
- Overshoot of defined limits
- Piston positions relative to cylinder
- Plunger positions relative to blank molds



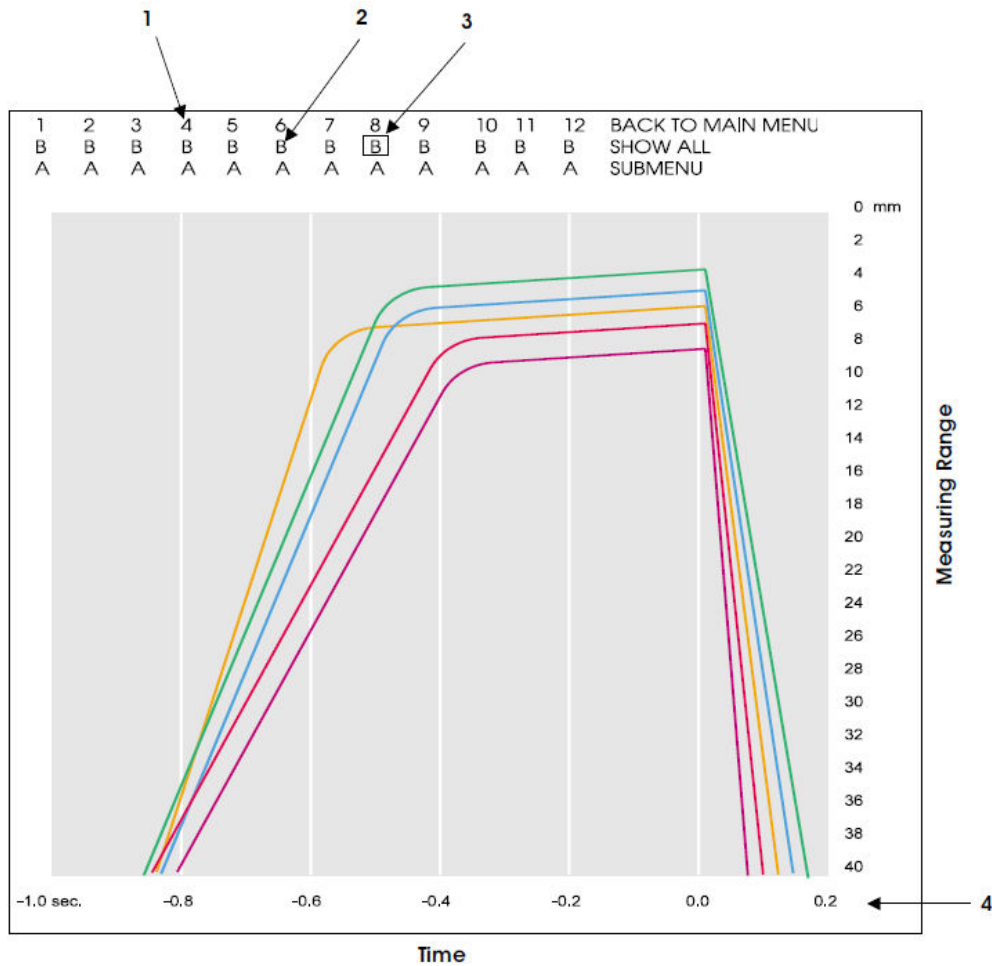
**Fig. 2:** Press Durations (Plunger Dwell Time)

- |                                   |   |
|-----------------------------------|---|
| 1. Section number                 | 3. Green bars for last 200 dwell times          |
| 2. Outer (A) and Inner (B) cavity | 4. Time base, selection at 0.5, 1.0 or 2.0 sec. |

The press duration above the horizontal time axis will be displayed for each mold as short vertical lines. Due to the fact that the press durations are only more or less reproducible, horizontal bars are formed. These bars represent the values of the last 200 machine cycles. The average value will be shown by a red line within each bar.

This displays shows:

- Press durations for the last 200 cycles of each blank mold
- Deviations of press durations
- Average press duration of each plunger
- Average press duration of all plungers



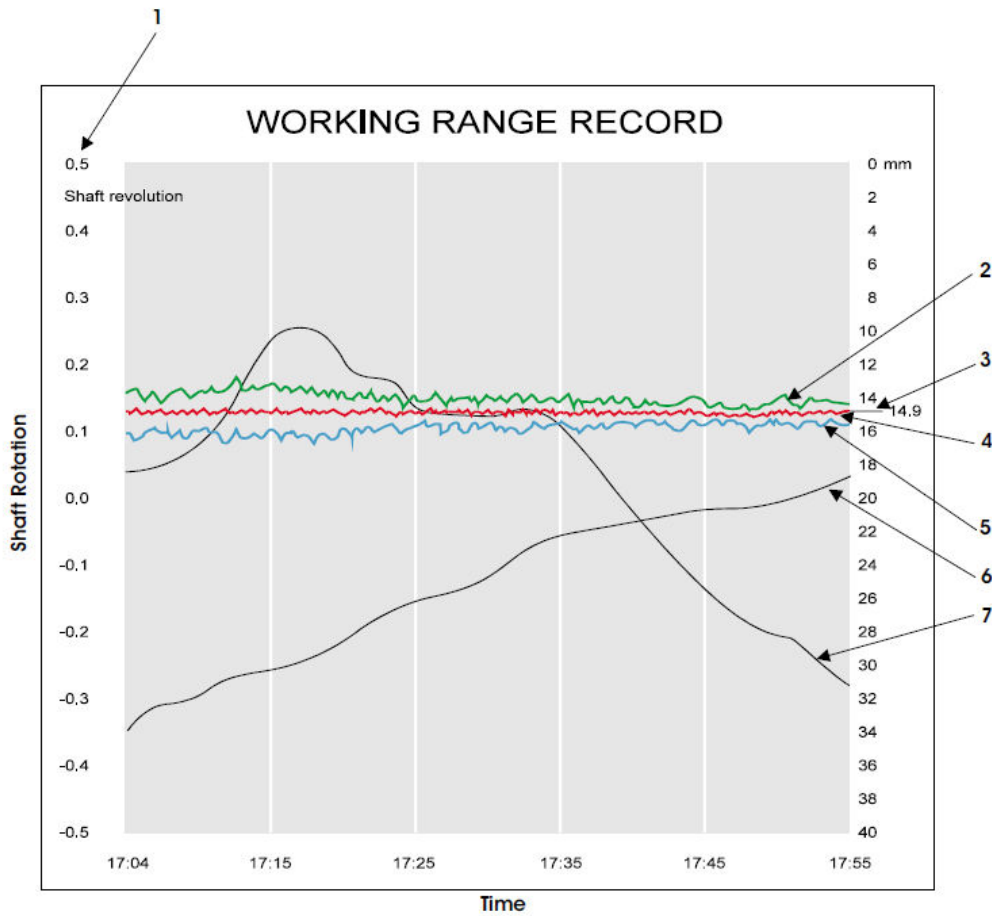
**Fig. 3:** PlungerMotions

- |                                   |                          |
|-----------------------------------|--------------------------|
| 1. Section number                 | 3. Selected cavity       |
| 2. Outer (A) and Inner (B) cavity | 4. Time axis, selectable |

This display shows:

- Piston movement of a selectable mechanism. The record is updated after each machine cycle.
- Movement of all mechanisms. The curves remain on the screen monitor.

This display permits recognition of incorrect movements and possible localization of causes of error.



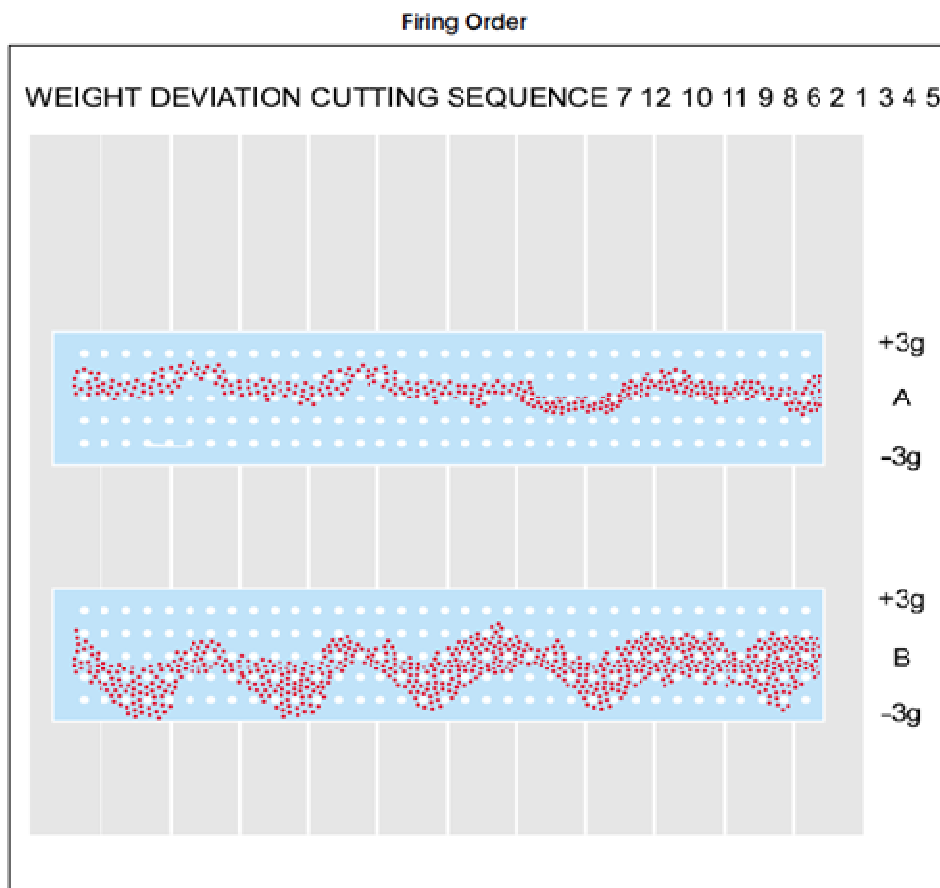
**Fig. 4:** Control Loop Function and Working Range

This histogram is a long-term record. The display covers 20,000 machine cycles.  
The display shows:

- |  |  |
|--|--|
| 1. Shaft revolution of remote control      | 4. Overall average of plunger end positions  |
| 2. Average end positions of outer plungers | 5. Average end positions of inner plungers   |
| 3. Setpoint value                          | 6. Activity of tube adjustment control loop  |
|  | 7. Activity of plunger position control loop |

After 100 records, the time is designated and the graph is shifted by one segment to the left. The characteristic feature of this graph is that the controller activities are shown. The shape of these lines shows the type of error which has influenced the process and for how long.

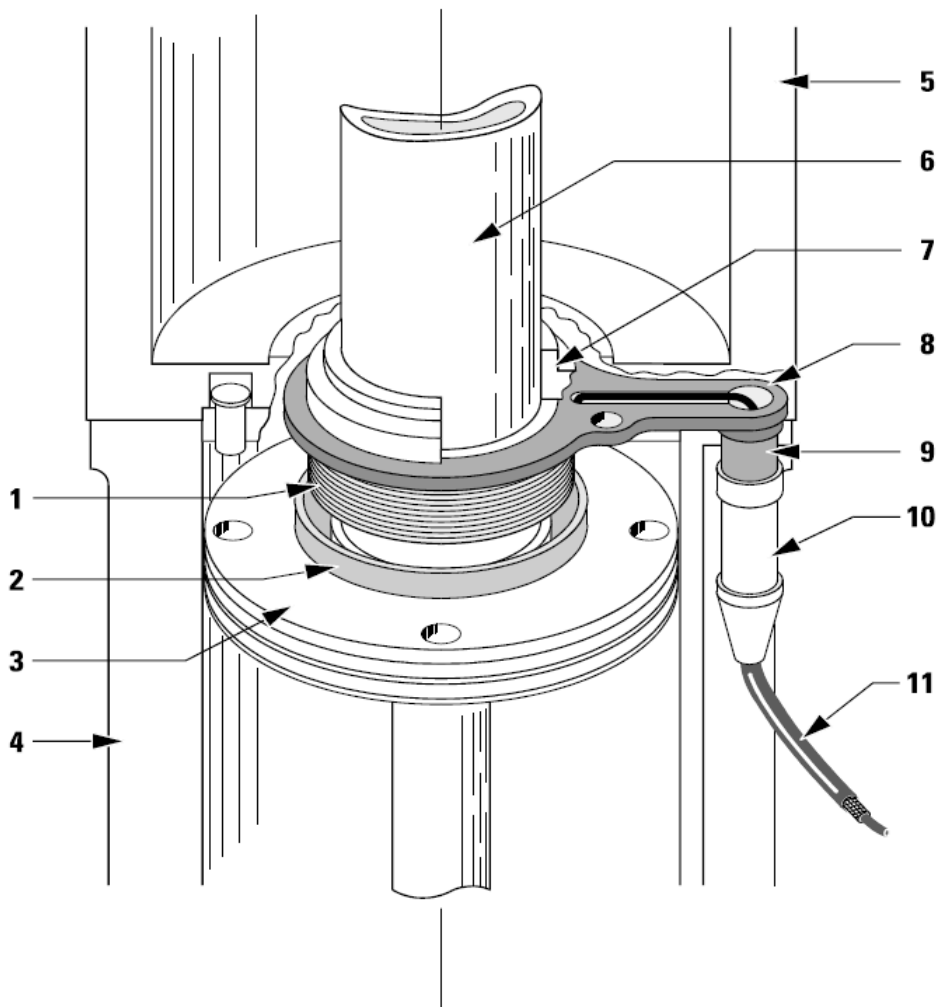




**Fig. 5:** Weight Deviation in Cutting Sequence

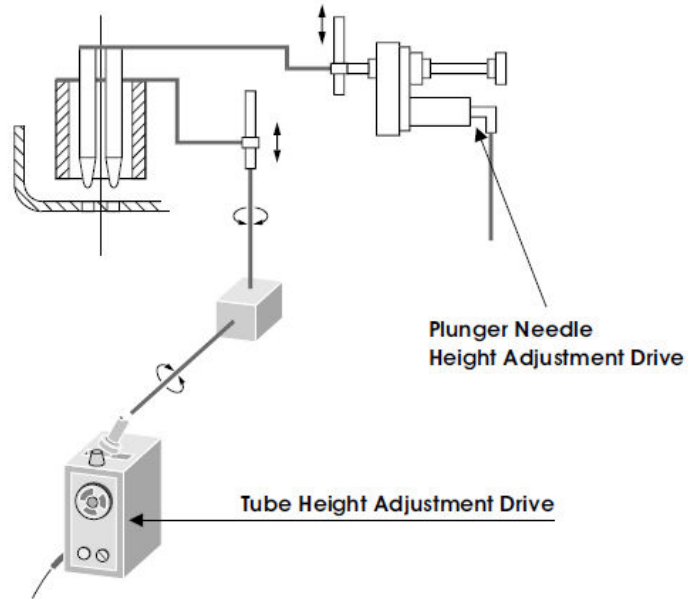
The display shows weight deviations for up to 1000 cuts. The plot reflects the cutting sequence. The shape of the curves shows the trend and course for short-term weight deviations such as:

- Influence of tube and rotors in feeder
- Influence of phase relationship between plunger and shear movement
- Condition of shears

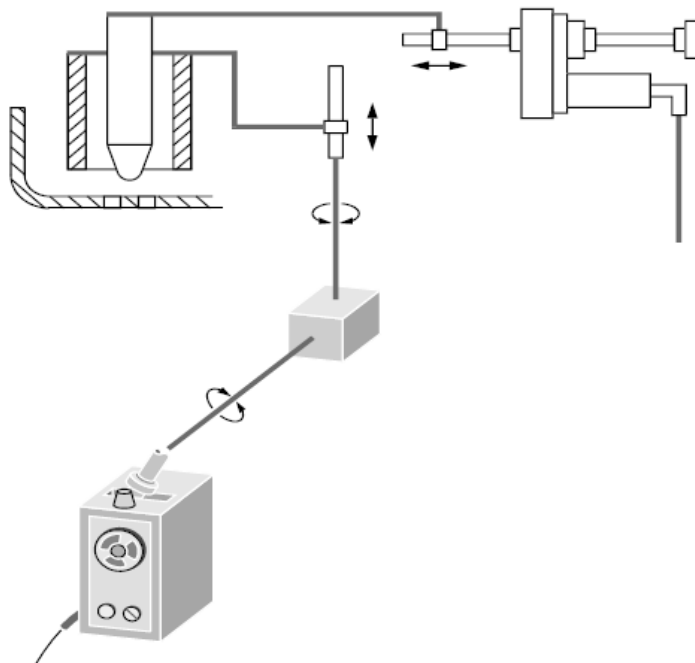


**Fig. 6:** Gob Weight Sensor in Plunger Mechanism

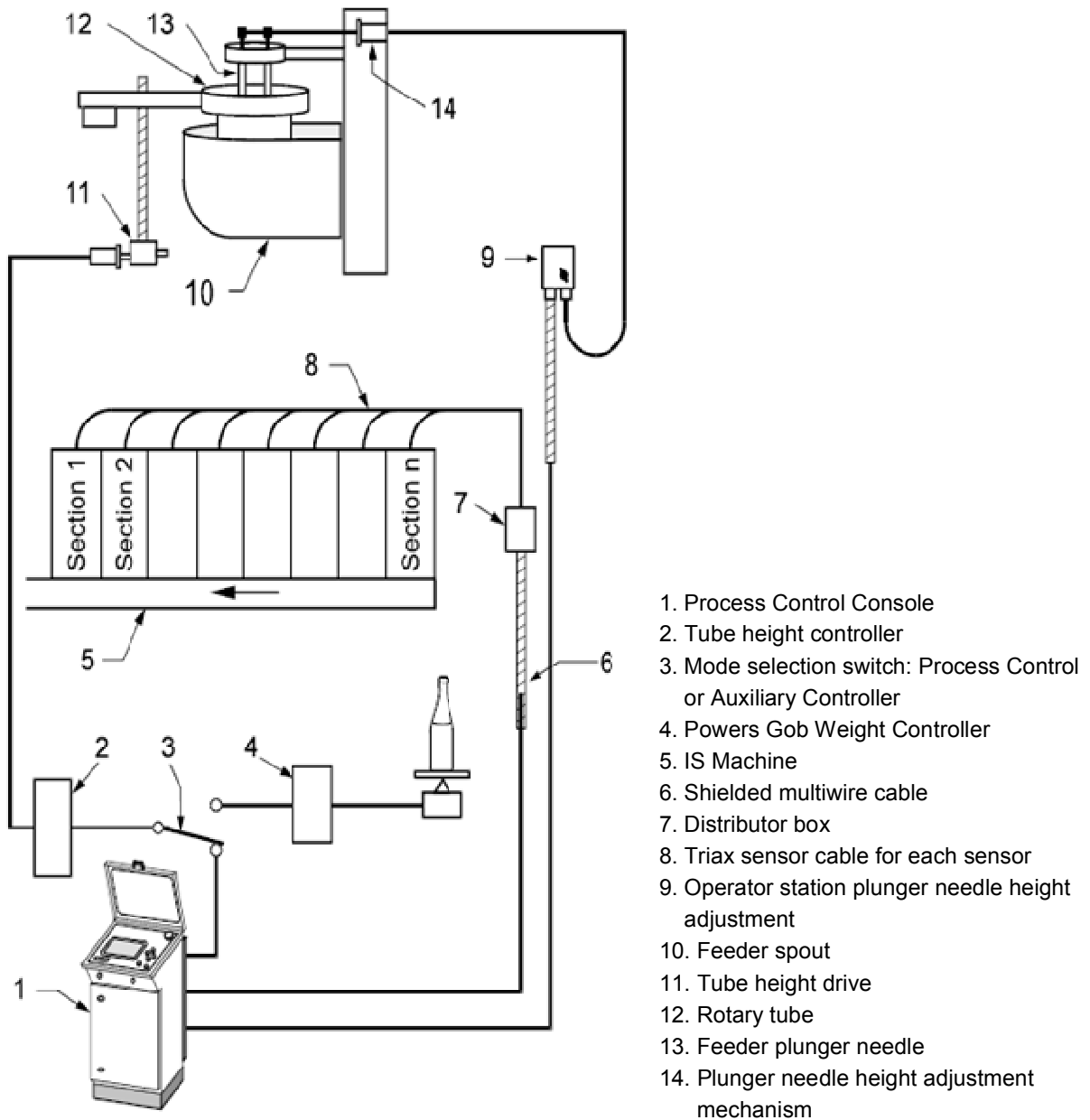
1. Sensor Coil
2. Aluminum Sleeve
3. Piston
4. Lower Cylinder
5. Upper Cylinder
6. Piston Rod
7. Bearing
8. Sensor Mounting Plate
9. Plug
10. Connector
11. Coax Cable



**Fig. 7 :** Mechanical feeder with tube and plunger height adjustment



**Fig. 8 :** Mechanical feeder with tube height and plunger position adjustment



**Fig. 9:** Block Diagram of 3000 Series Process Control